

# VS Serie Technische Details

VS Serie	Schnittlänge	Schneid-Kapazität		Hub pro min.	Schnitt-Winkel		Anzahl Niederhalter	Niederhalter-Stärke		Hinteranschlag Umfang
		MS (450 N/mm <sup>2</sup> )	SS (700 N/mm <sup>2</sup> )	Minimum - Maximum	Minimum	Maximum		Minimum	Maximum	
	mm	mm	mm	1/min.	°	°	mm	Tonnen	Tonnen	mm
A										
3006	3080	6	4	12 - 20	0° 30'	2°	16	4	20	1000
3010	3080	10	7,5	10 - 20	0° 30'	2°	16	4	20	1000
3013	3080	13	10	9 - 17	0° 30'	2° 30'	17	8	40	1000
3016	3080	16	12	7 - 12	0° 30'	2° 30'	14	11	55	1000
3020	3080	20	15,5	6 - 12	0° 30'	2° 30'	14	17	83	1000
4006	4080	6	4	10 - 20	0° 30'	2°	20	4	20	1000
4013	4080	13	10	7 - 13	0° 30'	2° 30'	20	10	48	1000
4016	4080	16	15	5 - 9	0° 30'	2° 30'	17	50	100	1000
4020	4080	20	15,5	4 - 8	0° 30'	2° 30'	21	50	100	1000
6006	6080	6	4	6 - 10	0° 30'	2°	29	10	20	1000
6013	6080	13	10	5 - 10	0° 30'	2° 30'	29	29	58	1000
6016	6080	16	12	4 - 10	0° 30'	2° 30'	29	29	58	1000
6020	6080	20	15,5	3 - 6	0° 30'	3° 15'	29	48	100	1000
6025	6100	25	19	3 - 6	0° 30'	3° 25'	30	150	250	1000
8010	8100	10	7,5	3 - 6	0° 30'	2°	40	40	60	1000
10013	10100	13	10	3 - 6	0° 30'	2° 12'	52	60	81	1500

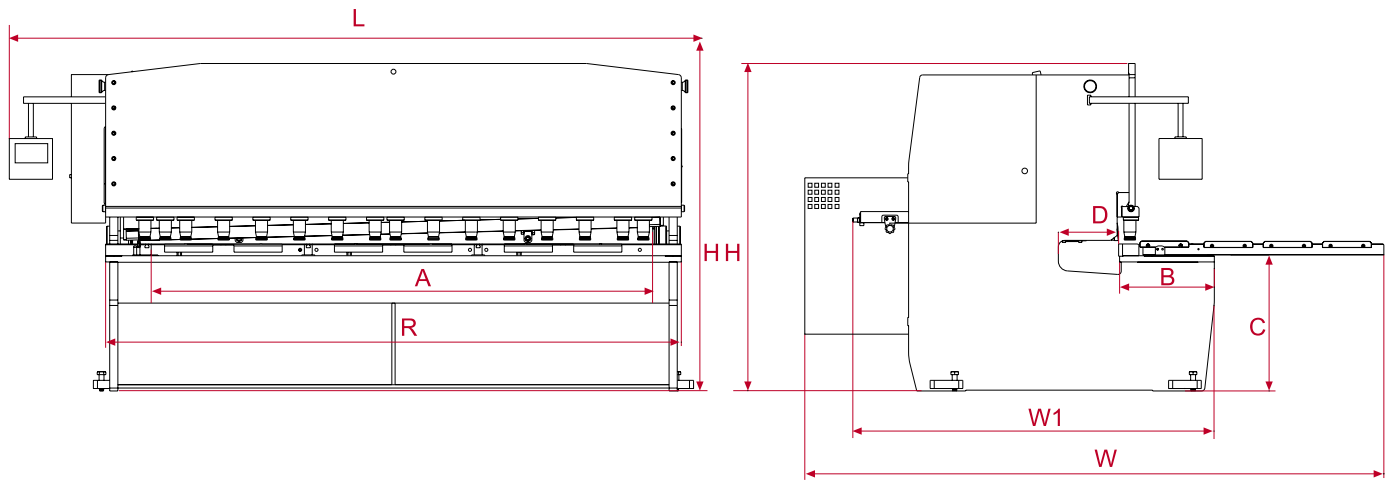

Hinteranschlag Geschwind-	Motorleistung	Öl Kapazität	Ausladung	Vorderarme	Tischhöhe	Tischbreite	Tischlänge	Länge	Breite	Gesamtbreite	Höhe	Gewicht
mm/sek.	kW	lit	mm	Anzahl	mm	mm	mm	mm	mm	mm	mm	~kg
			D		C	B	R	L	W1	W	H	
200	11	125	350	3	820	494	3280	4100	2050	3650	1950	7980
200	22	180	350	3	820	554	3360	3800	2050	3550	2150	9300
200	30	300	350	3	835	559	3380	4200	2100	3560	2450	12860
200	45	450	350	3	840	554	3420	4130	2210	3820	2570	18150
200	45	500	350	3	840	580	3460	4100	2300	3700	2650	21400
200	11	125	350	4	820	494	4400	5150	2100	3550	2050	10470
200	30	330	350	4	835	589	4400	5200	2150	3560	2550	17720
200	45	400	350	4	1000	630	4385	5890	2100	3625	2950	24400
200	45	500	350	4	1000	630	4405	5900	2200	3775	2950	30320
200	22	200	350	6	900	630	6370	7300	2150	3400	2750	25500
200	37	400	350	6	950	650	6375	7400	2200	3700	2900	33820
200	45	550	350	6	950	650	6375	7400	2200	3790	2950	39300
200	45	700	350	6	1000	800	6595	8100	2800	4100	3530	61000
200	55	750	350	6	1000	900	6750	7850	2900	4250	3400	72000
200	30	550	500	7	1220	850	8545	9100	3350	4200	3280	87000
200	45	650	750	9	1210	860	10630	11500	3400	4240	3800	147000