

SBT Series Technical Details

SBT Series	Cutting Length	Cutting Capacity		Throat Depth	Stroke per min.	Cutting Angle	Holddowns	Holddown Force	Back Gauge Range	Back Gauge Force
		MS (450 N/mm ²)	SS (700 N/mm ²)							
	mm	mm	mm	mm	1/dak.	°	Birim	Ton	mm	kW
	A			D						
3006	3100	6	4	50	15	1° 30'	16	14	1000	0,75
3010	3100	10	6	50	13	1° 30'	16	22	1000	0,75
3013	3100	13	8	50	13	1° 45'	16	37	1000	0,75
3016	3100	16	10	350	10	2°	14	61	1000	0,75
3020	3100	20	13	350	6	2°	14	77	1000	0,75
4006	4100	6	4	50	12	1° 30'	20	17	1000	0,75
4013	4100	13	8	350	8	1° 45'	18	62	1000	0,75

Standard & Optional Equipment

Standard Equipment

Heavy duty St 44 steel construction & stress relieved frame
 User friendly CNC Touch screen control unit D-Touch 7
 Easy blade gap adustment
 Ball integrated front tables
 Ballscrew back gauge, 1000 mm & automatic swing-up
 Squaring arm with scale & T-Slot & tilting stop
 Support arms T-Slot & Tilting stop
 Illumination & shadow line1 mt flip-up finger guards
 Automatically pressure adjusted solid holddowns
 Top blades with 2 sides and Bottom blades with 4 sides
 Foot pedal
 High performance hydraulics & electronics components
 Automatic Swing-up back gauge
 CE-Norm

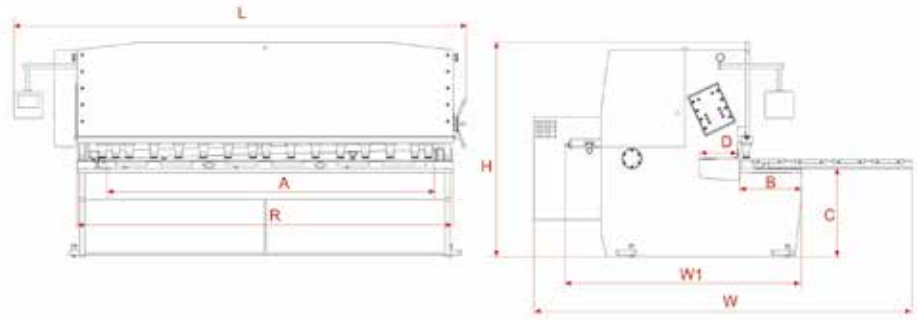

Back Gauge Speed	Motor Power	Oil Capacity	Front Armas	Tabla Height	Table Width	Table Length	Length	Width	Total Width	Height	Weight
mm/sn.	kW	lt	Unit	mm	mm	mm	mm	mm	mm	mm	~kg
				C	B	R	L	W1	W	H	
200	15	200	2	865	500	3515	4110	2200	3700	2100	7300
200	22	200	2	865	580	3515	4200	2250	3600	2100	9050
200	30	330	2	845	600	3550	4280	2300	3600	2350	11800
200	37	410	2	818	550	3580	4550	2250	3825	2250	14580
200	45	450	2	886	570	3670	4450	2260	3400	2450	20480
200	15	200	3	865	580	4510	5230	2300	3600	2150	11460
200	30	330	3	818	550	4520	5350	2250	3650	2250	16300

Optional Equipment

- Motorized blade gap adjustment
- Laser cutting line
- Light curtains for finger protection
- Pneumatic thin sheet support DURMA I
- Pneumatic thin sheet support DURMA IV
- Special throat depth
- Backgauge 1250 mm.
- Add. support arms
- Special blades
- Oil coolant
- Oil Heater
- Adjustable angle stop 0-180°
- Control panel on opposite position
- Temperature measurement
- Overseas special packaging