

Fiber Laser

Technologies

HD-F / HD-FL

HD-F COMBI

HD-F BH

HD-FA

HD-FO



Easy
to Use

High Quality
Cutting

Low Energy
Consumption

Faster

Efficient

Winning

Ergonomic



As a total supplier for sheet metal manufacturing with almost 70 years of experience, Durma understands and recognizes the challenges, requirements and expectations of the industry. We strive to satisfy the ever higher demands of our customers by continuously improving our products and processes while researching and implementing the latest technologies

In our three production plants with a total of 150.000 m², we dedicate 1,000 employees to delivering high quality manufacturing solutions at the best



PRODUCTION IS
MORE EFFECTIVE NOW

performance-to-price ratio in the market.

From the innovations developed at our Research & Development Center to the technical support given by our worldwide distributors, we all have one common mission: to be your preferred partner.

Durmazlar offers its machines to the world markets under the Durma brand.



1

High technology,
modern production
lines



2

Top quality
components

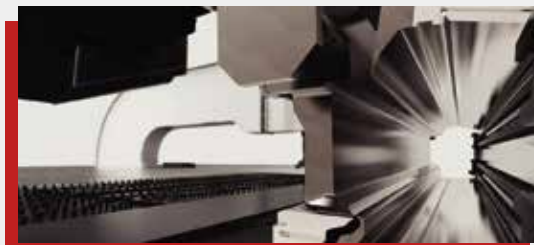

3

High quality
machines designed
in R&D Centre

FIBER LASER

- Low operating cost and energy consumption
- Globally recognized high performance components
- Precise cuts and high durability
- High profit margin

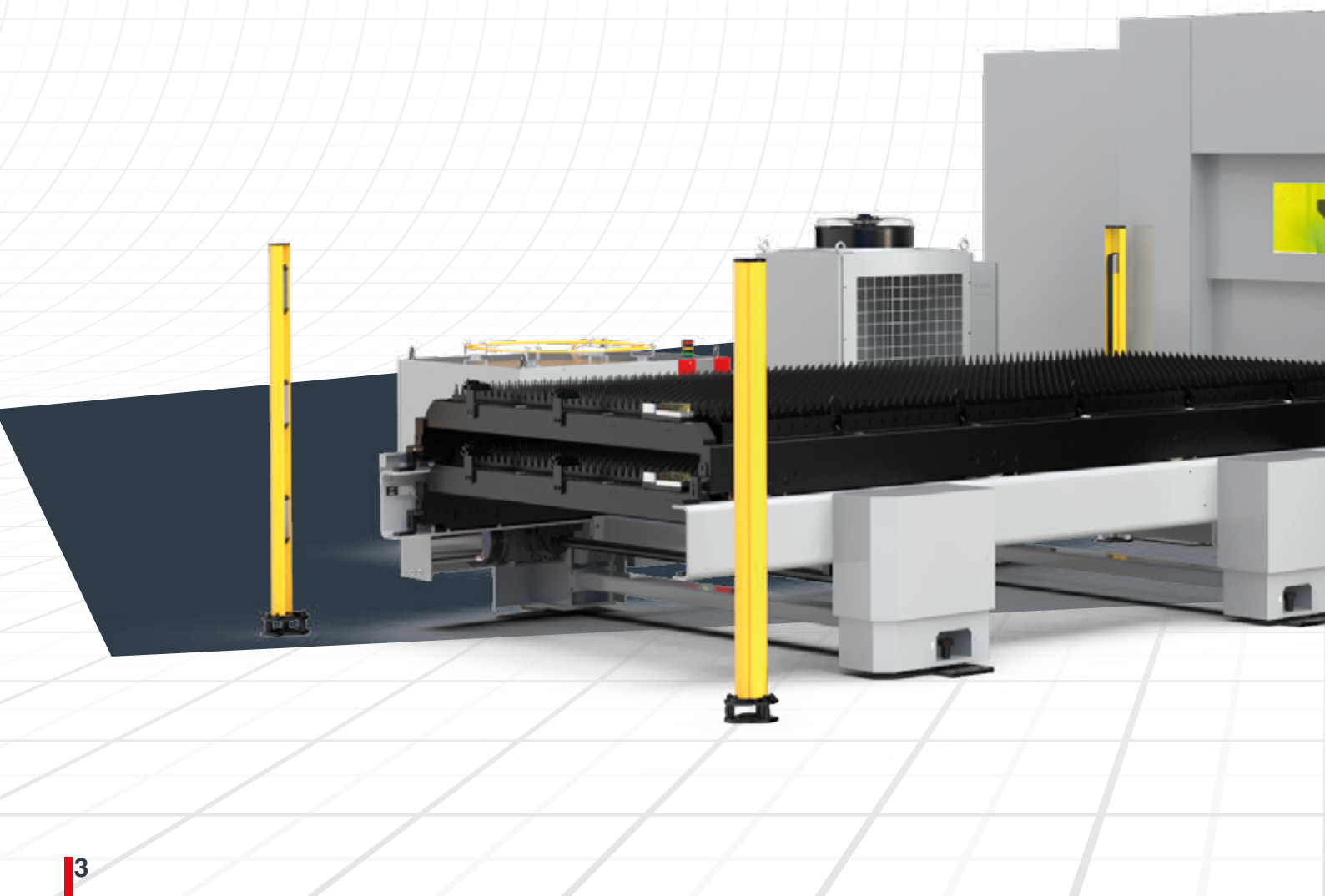

Production is *More Effective Now.*

Fiber Lasers Provide Innovative Solutions

- Perfect results on variety of material
- Efficient and precise cuts on thick and thin material
- Low investment and operating costs
- Modern and compact design
- Fast service with remote control



FIBER LASER

Fiber Laser Technologies

Fiber lasers outshine with its fast cutting and energy efficiency abilities when especially its compared to CO₂ lasers. Easy use, maintenance and service has been achieved by the high technology of Fiber Lasers. Globally recognized efficient components used in *DURMA* Fiber Lasers add value to your company.

Rack & Pinion and Linear Motor Motion technologies allows us achieve 3G acceleration. We always strive to serve quality, performance and efficiency to our clients.

DURMA Fiber Laser is unrivaled with its rigid body structure, perfect filtration system, compact design, efficiency and user friendliness.

■ Rack and Pinion Motion System (HD-F Series)

Axes motion is achieved by rack and pinion design. There are not any intermediate load transmitting elements between the motor and the pinion which otherwise could cause precision losses. High precision two-day, hardened helical racks with low clearance make it possible to achieve very high acceleration (synchronized 28 m/s²), speed (synchronized 170 m/min.) and accuracy (0,05 mm) values.



■ Linear Motor Motion System (HD-FL Series)

Moving axes are driven by high velocity and acceleration linear motors which are the latest development in linear technology. These motors make it possible to achieve very high acceleration (synchronized 35 m/s²), speed (synchronized 280 m/min.) and accuracy (0,03 mm) values.



Fiber Laser Power Source

Resonator	4.0 kW	6.0 kW	10.0 kW	12.0 kW	15.0 kW	20.0 kW	30.0 kW
Product designation	YLS-4000	YLS-6000	YLS-10000	YLS-12000	YLS-15000	YLS-20000	YLS-30000
Available operation modes	CW, QCW, SM						
Polarization	Random						
Available output power	400-4000 w	600-6000 w	1000-10000 w	1200-12000 w	1500-15000 w	2000-20000 w	3000-30000 w
Emission wavelength	1070 -1080nm						
Feed fiber diameter	Available in single mode, 50, 100, 200, 300µm						
Ancillary Options	Options Available: Internal coupler, Internal 1x2 beam switch, Internal 50:50 beam splitter, External 1x4 or 1x6 beam switch						
Interface	Standard: LaserNet, Digital I/O, Analog Control Additional Options: DeviceNet or Profibus						

Material (Cutting Capacity)*	YLS 4000 (4kW)	YLS 6000 (6kW)	YLS 10000 (10kW)	YLS 12000 (12kW)	YLS 15000 (15kW)	YLS 20000 (20kW)	YLS 30000 (30kW)
Mildsteel (s235jr)	20 (22) mm	25 mm	30 mm	30 mm	35 (40) mm	40 (50) mm	50 (60) mm
Stainless Steel (1.4301)	10 (12) mm	15 (20) mm	25 (30) mm	25 (30) mm	35 (40) mm	40 (50) mm	50 (60) mm
Aluminum (AlMg3)	12 (15) mm	20 (25) mm	25 (30) mm	30 (40) mm	35 (40) mm	40 (50) mm	40 (50) mm
Copper	6 mm	10 mm	15 mm	15 mm	15 mm	15 mm	15 mm
Brass	10 mm	12 mm	20 mm	20 mm	20 mm	20 mm	20 mm

*Standard cutting parameters.

Factors such as rust, shell formation, paint, label, pitch shifts on the surface, rolling defects, rusts on the surface of the material, affect the black sheet cutting negatively. The top and bottom surfaces of the material to be cut must be clean. The cutting quality and cutting speeds of sandblasted sheets vary.

Low Operating Costs

- Low energy consumption
- Low cost per component
- Optimised focal distance for all thickness values
- Maintenance free operation
- Compact design, fast installation
- Rigid body structure, high durability

FIBER LASER

Laser Cutting Head

The ProCutter offers a complete solution for the laser-based fusion cutting of thin and medium material thickness in the wavelength range around 1µm. In flame cutting, greater material thicknesses can also be processed while maintaining high standards of quality. The potential of the cutting head is optimally converted into productivity, especially in the case of flatbed and pipe cutting machines, where innovative technologies are combined with proven concepts, providing the best possible performance, range of flexibility and degree of reliability.

The combination of proven technology and optimized design enables processing with up to 40 kW laser power in the near-infrared range - and gives you reduced installation space and weight at the same time. A robust and dustproof housing ensures a long service life and allows external linear drive accelerations up to 4.5 g enabling an efficient cutting operation. High-quality optics and the highest standards of quality in manufacturing and assembly ensure optimum laser beam guidance and shaping with high focal position stability, even at high laser power.

■ Efficient

- Lightweight and slim design created for fast acceleration and cutting speed
- Motorized focus position adjustment for automatic machine setup and piercing work
- Drift-free, fast-reacting distance measurement
- Permanent protective window monitoring
- Values displayed via bluetooth

■ Flexible

- Selectable optical configuration, optimized for the range of applications
- Straight and angled design versions adapted to the machine concept
- Zoom lens for automatically adjusting the focus diameter
- Motorized or manual focal position adjustment

■ User Friendly & Safe

- Completely dustproof beam path with protective windows
- LED operating status display
- Display of operating parameters via Bluetooth® and interface for machine control
- Pressure monitoring in the nozzle area (gas cutting) and in the head
- Monitoring of the piercing process and detection of cutting breaks with CutMonitor



App for iOS and Android gadgets

Production is *More Effective Now.*

Dynamic laser cutting machines require smart cutting heads for its operations. ProCutter offers a fully-integrated sensor system that monitors the cutting process and provides the relevant information to the user. The ProCutter ensures that each component can be re-manufactured at a high standard of quality.

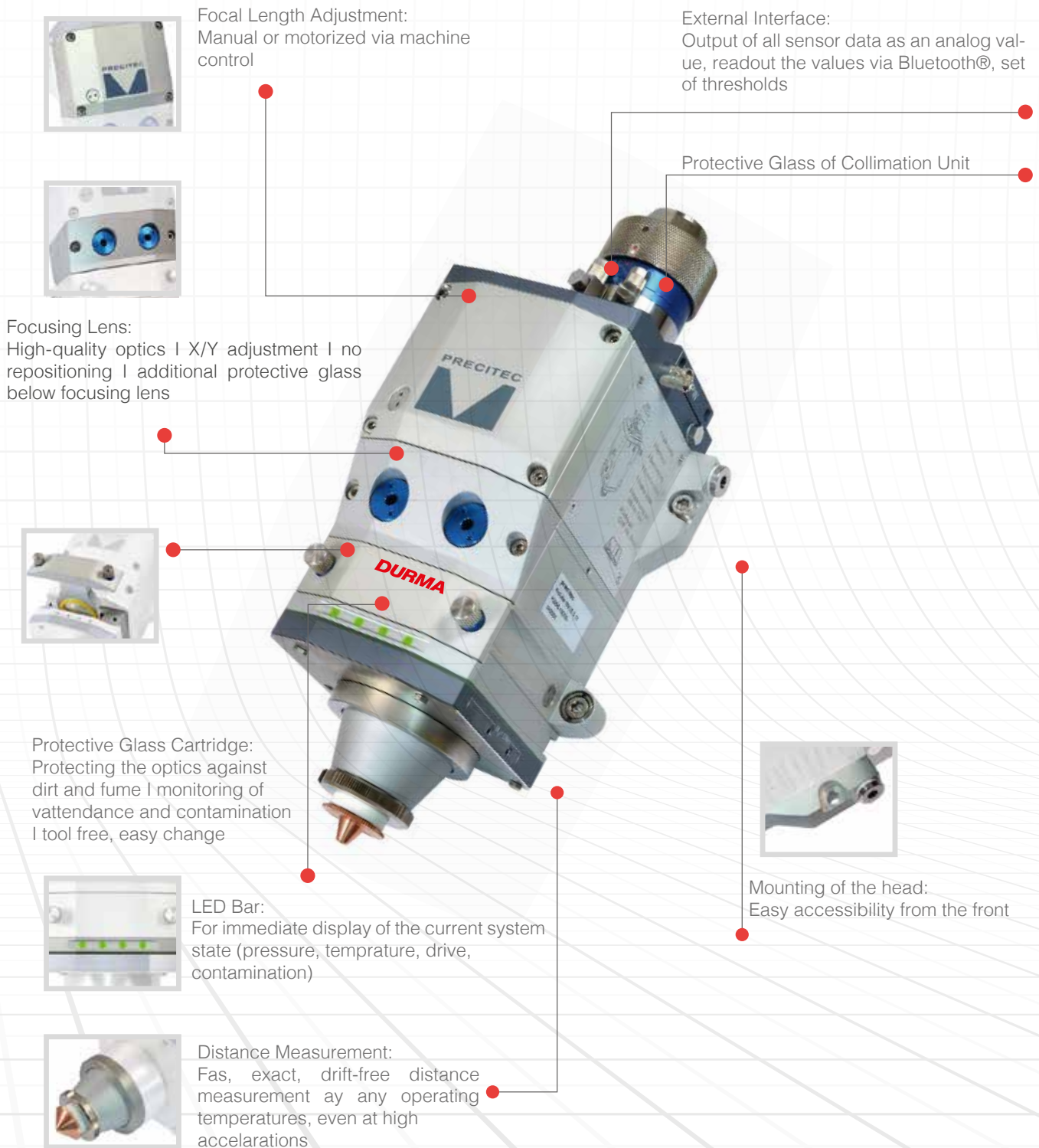

FIBER LASER

■ Higher Acceleration on Z-Axis

Lighter and strongly rigid bridge does not allow it to vibrate at high speed and obtain high accurate cutting geometry.

Equipped with world's favorite head "Precitec". During the construction of the bridge all kind of deformations analyzed and prevented.



■ Shuttle Table

Servo controlled shuttle table system applied to HD-F 3015 (Standard) and HD-F 4020 (Option) series machines reduces the changeover times by 40%. For 3015 series it drops down to 19 sec. and for 4020 series, to 29 sec.

The shuttle table is fully automatic and maintenance-free on all machines. Hydraulic oil is not used and changing the table is fast, soft and has low energy cost.

Table change time is 40 seconds in HD-F 4020 series, and 45 seconds in the HD-F 6020 series. Back and forth movement of all tables are performed with servo motors.

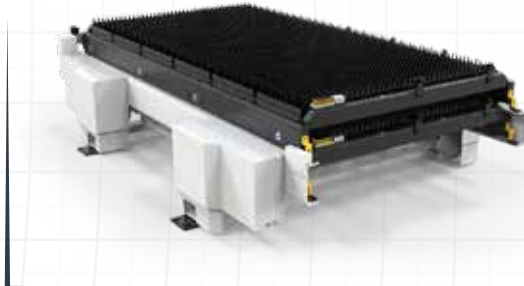

■ Multi Chambers High Efficient Suction System

With the multi chambers high efficient system offers the ability to make an equal amount of suction during the cutting operation of the whole machine cutting area.

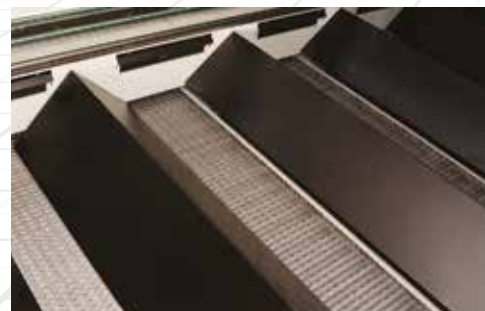

■ Easy Access Side Door

There is standart side door to access the back part of the cutting sheet and correct the cutting parts positions during the operation. This side door also used by the service team of the laser machine when the maintenance will be done.



■ Scrap Conveyor

The optional lateral automatic scrap conveyors allow the removal of scrap pieces from the working area without the need to interrupt the cutting process. The sideways operation of the short conveyors allow for easy maintenance and trouble-free running.



■ Bevel Head $\pm 45^\circ$

Bevel Head for vertical and bevel cuts from 0° to 45° . Optimal results provided through the combination of 5 axis interpolation and software. Positive and negative bevel angles in one part.



FIBER LASER

Control Panel

The controller has a Durma operator interface and a complete cutting database for all standard cutting applications. The database includes the cutting parameters for standard materials (steel, stainless steel, aluminum) for common thickness ranges. Based on these reference values the operator can easily improve the cutting quality for different types of materials.

- Sinumerik 840 D SL
- IFP1900 19" Touch Screen
- IPC427 E Intel I5-6442EQ
- 8GB SD Ram DDR3WIN10/SSD 240 GB
- Ethernetx3
- USBx4
- PCI x1
- CF Card
- DPP



Durma Cloud

Actual state of machine can be traced,
 Operator can leave machine when program is too long
 Cutted parts can be reported,
 Retrospective or periodic reports can be created,
 Cost calculations can be done,
 Consumption calculations can be done,
 Running duration, standby duration, productivity calculations can be done,
 Error messages and error reasons can be inspected



CAD/CAM Software

- Advanced optimisation: tools optimisation
- Fast tool way collision protection. Toolway optimisation to prevent damage from possible deformed material
- Writings supported by your operating system can be applied directly on the material to be cut
- Cutting direction, clockwise or opposite is supported
- Advanced corner applications provide perfect corners and soft cutting.
- Fillets, cooling, slowing down, circulation
- Shared Cuttings: This function is especially useful for thick plates and reduces the need of marking holes during cutting
- Automatic entry point
- Fully automatic cutting
- Z-Axis control

Lantek - Metalix



Lantek



Metalix



Lantek inside



Metalix
MT software

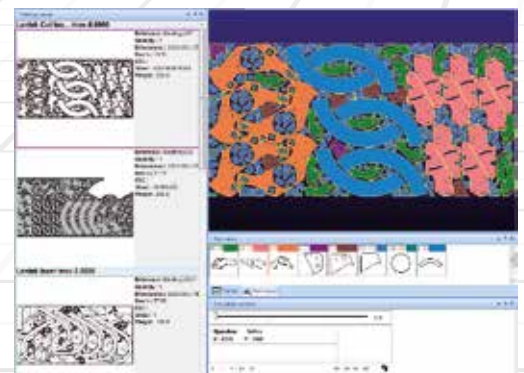

Experience the Difference of DURMA HD-FL

Chiller

DURMA Laser power source and cutting head is chilled with specially designed, low energy consuming, high efficient chiller unit.

Filter

Used to eliminate dust, particles and harmful fumes, generated during cutting. It is fully automatic dust collecting shake filter.

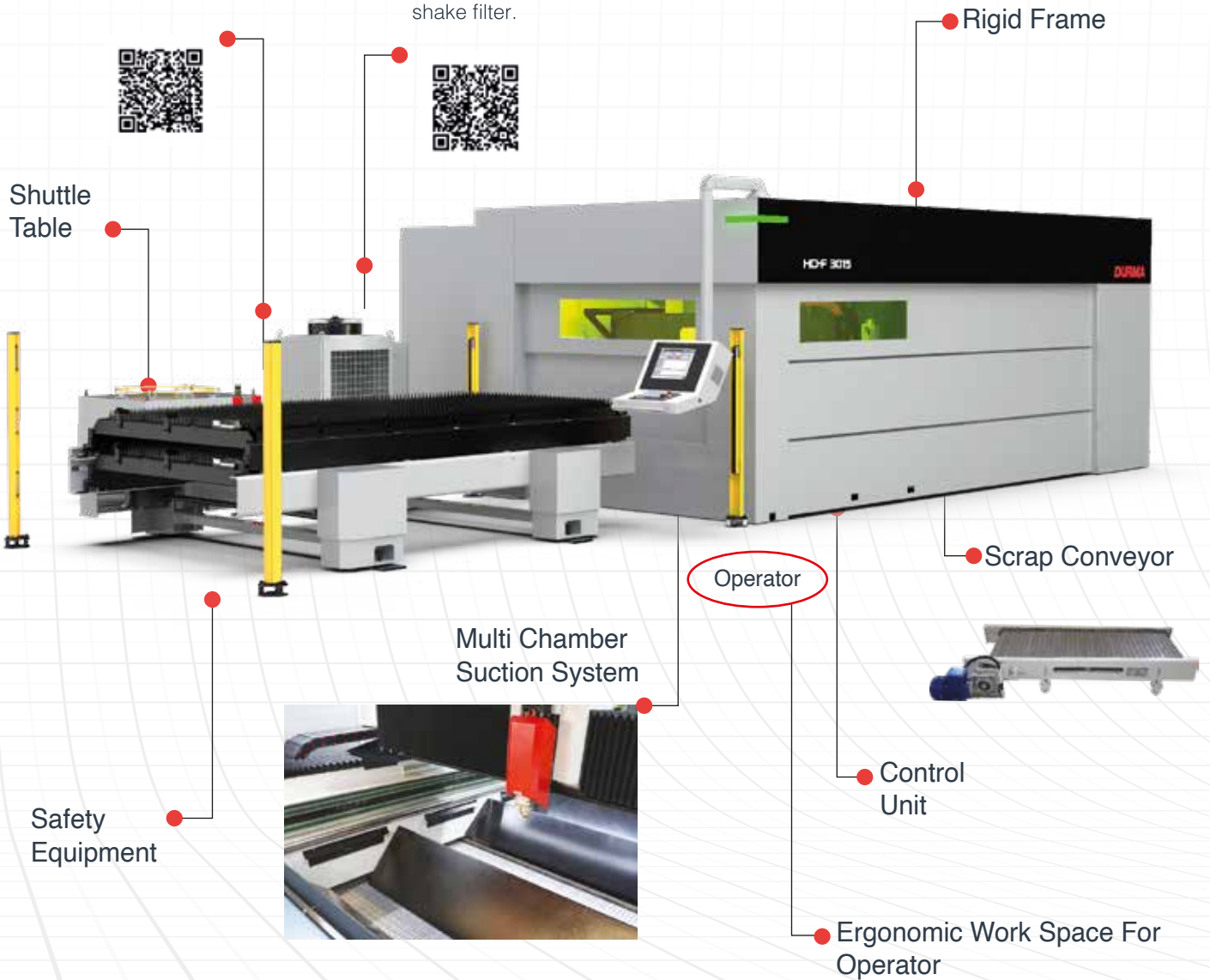

FIBER LASER

HD-F / HD-FL FIBER LASER

	3015	4020	6020	8020	12020	
X Axis	3060	4100	6150	8200	12200	mm
Y Axis	1530	2100	2100	2100	2100	mm
Z Axis	160	185	185	185	185	mm
Max. Sheet Size	3048 x 1524	4064 x 2032	6096 x 2032	8128 x 2032	12192 x 2032	mm
Max. Sheet Weight	315	315	315	315	315	kg/m ²
	Rack & Pinion HD-F		Lineer System HD-FL			
X Axis	120		160		m/min.	
Y Axis	120		160		m/min.	
Synchronous	170		226		m/min.	
Acceleration	28		35		m/s ²	
Positional Accuracy	±0,05		±0,03		mm	
Repeatability	±0,05		±0,03		mm	



Production is *More Effective Now.*

➤ User
Friendly

➤ Ergonomic

➤ Efficient

➤ Fast

➤ Reliable
Brand



FIBER LASER

HD-F / HD-FL BH 2D Pipe and Profile Cutting

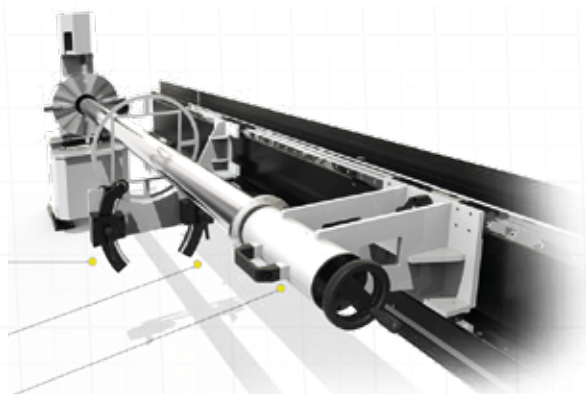

Tube – Profile Cutting Technical Features

Cutting length	mm	3000 mm (Chuck 6000 mm through, $\lt; \varnothing 130\text{mm}$)
Maximum tube loading	Kg	120
Laser power supply		2-10 kW
Working diameter	min./max	$\varnothing 30 / \varnothing 400$
Max. tube thickness	mm	Up to 12 mm depending on material and laser power
Square profile cutting	max.	250 x 250
Max. positioning speed X / Y	m/min.	100
Cutting accuracy	mm	+/- 0,5 / 1000
Materials		Mildsteel / Stainless / Aluminum / Copper / Brass

Production is *More Effective Now.*

HD-F COMBI 2D Cutting & Pipe and Profile Cutting



Pipe - Profile Cutting Technical Data (HD-F 3015 & HD-F 4020 & HD-F 6020)

Max. Pipe Diameter	170	mm
Max. Square Profile Dimension	120 x 120	mm
Max. Rectangle Profile Dimension	150 x 100	mm
Min. Pipe Diameter	20 (12 Opt.)	mm
Max. Material Length	6500	mm
Max. Material Length for Auto Unloading*	4500	mm
Max. Material Length for Manual Unloading**	6000	mm
Max. Material Weight	37,5	kg/m
Max. Total Material Weight	210	kg
Cutting Tolerance***	±0.2	mm

* 6500 mm for HD-F 6020

** 6500 mm for HD-F 6020

*** The maximum cutting precision on the part depends on the type of profile and the production method.

FIBER LASER

HD-FO FIBER LASER



HD-FO 3015

DU

Production is *More Effective Now.*



Production is *More Effective Now.*

HD-FO FIBER LASER

HD-FO Technical Data

Cutting axes		
X Axes	3048	m/min.
Y Axes	1530	m/min.
Z Axes	125	m/min.
Max. Sheet Dimensions	3.048 x 1.524	mm
Max. Sheet Weight	575	Kg

Dynamics

Max. Speed X Axis	90	m/min.
Max. Speed Y Axis	90	m/min.
Max. Speed Z Axis	30	m/min.
Max. Synchronized Speed (X-Y)	127	m/min.
Max. Synchronized Acceleration	14	m/s ²
Positioning Tolerance	±0,05	mm
Repeatability	±0,05	mm

Control Unit

CNC	BOSCH REXROTH
Screen	19" Touch Screen

Laser Cutting Head

Type	DURMA
Focal Distance (mm)	150
Focal Type	Auto

Material Cutting Thickness (mm)

Material	YLR 1000 (1kW)	YLS 2000 (2kW)	YLR 3000 (3kW)	YLS 4000 (4kW)
Mild Steel (s235jr)	8	12	16	20
Stainless Steel (1.4301)	4	6	8	10
Aluminium (AlMg3)	4	6	8	12
Copper	2	3	5	6
Brass	4	6	8	10

FIBER LASER

■ MANUAL CUTTING TABLE

The machine is designed especially for the customers who has layout problems. Sheet loading and unloading is extremely easy in cases where no shuttle table is needed.



■ COMPACT, MODERN AND ERGONOMIC LAY-OUT

Helping of the compact layout of the machine, sheet loading, cutting and unloading operations are performed by using less space and less operations.

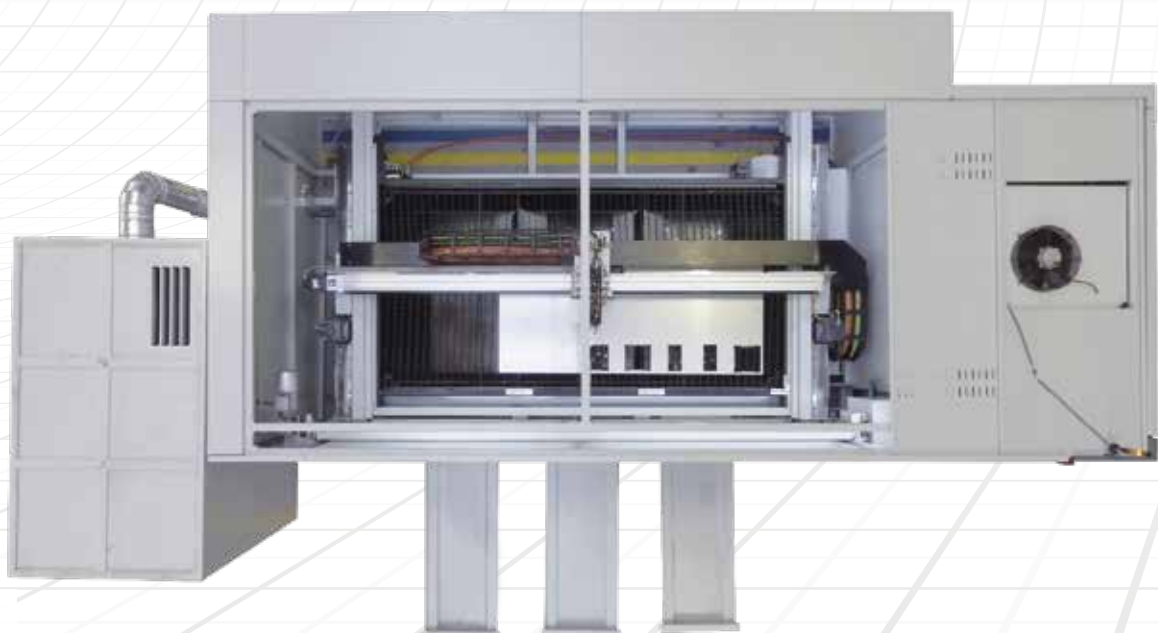

■ **PNEUMATIC SHUTTLE TABLE (OPTION)**

As standard there is a manual cutting table. Optionally, with your 1 or 2 KW power source order, you can get a pneumatic shuttle table.



■ **EASY ACCES TO CUTTING AREA WITH BACK DOOR**

Rear door for use when cutting is required. This rear door is also used during machine maintenance



FIBER LASER

HD-FA 5 AXIS LASER

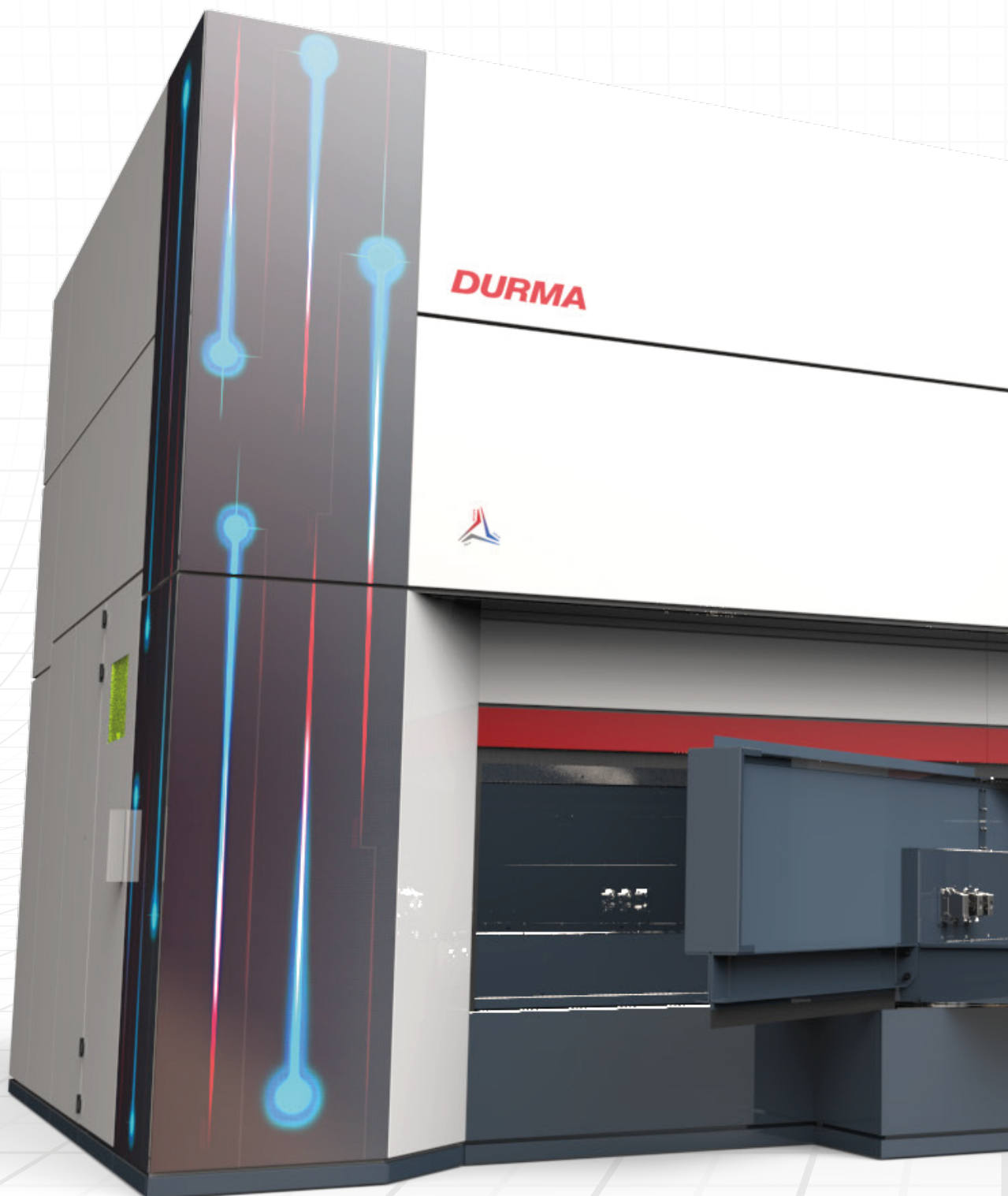

Production is *More Effective Now.*

➤ User
Friendly

➤ Ergonomic

➤ Efficient

➤ Fast

➤ Reliable
Brand



Production is *More Effective Now.*

HD-FA TECHNICAL SPECIFICATIONS

X axis stroke	3.000 mm
Y axis stroke	1.500 mm
Z axis stroke	650 mm
B axis	±135°
C axis	±360°xn
Max. Synchronous Speed	173 m/min.
Max. Synchronous Acceleration	1,73 G
Positional Accuracy	±0.08 mm
Repeatability	±0.08 mm

MACHINE SIZES

Machine Size	6168 mm x 3936 mm h= 3700 mm
Working Area	9.000 mm x 10.000 mm (Secure area)
Rotary Table's Door Length	4.000 mm
Machine Weight	16.000 kg

CUTTING THICKNESS mm

Power	2 kW	3 kW	4 kW
Mild Steel (mm)	12	16	20
Stainless (mm)	6	8	10
Aluminum (AlMg3) (mm)	6	8	12
Brass (mm)	6	8	10
Copper (mm)	3	5	6

CUTTING HEAD

Type	3D
Focus	Automatic

CONTROL UNIT

CNC	SIEMENS SINUMERIK 840D SL
Screen	19" Touch panel

FILTER

Capacity	2.500 m ³ /h - 4 kW
----------	--------------------------------

CHILLER

Chiller for 2 kW	IPG LG 71
Chiller for 3 kW	IPG LG 170
Chiller for 4 kW	IPG LG 171

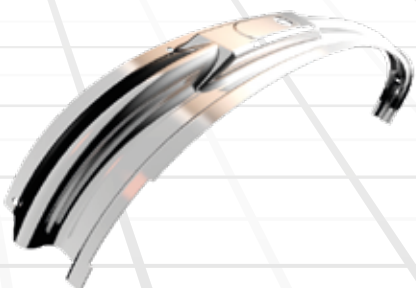

FIBER LASER

SPECIAL APPLICATIONS

Turkey's Biggest and Fastest Laser

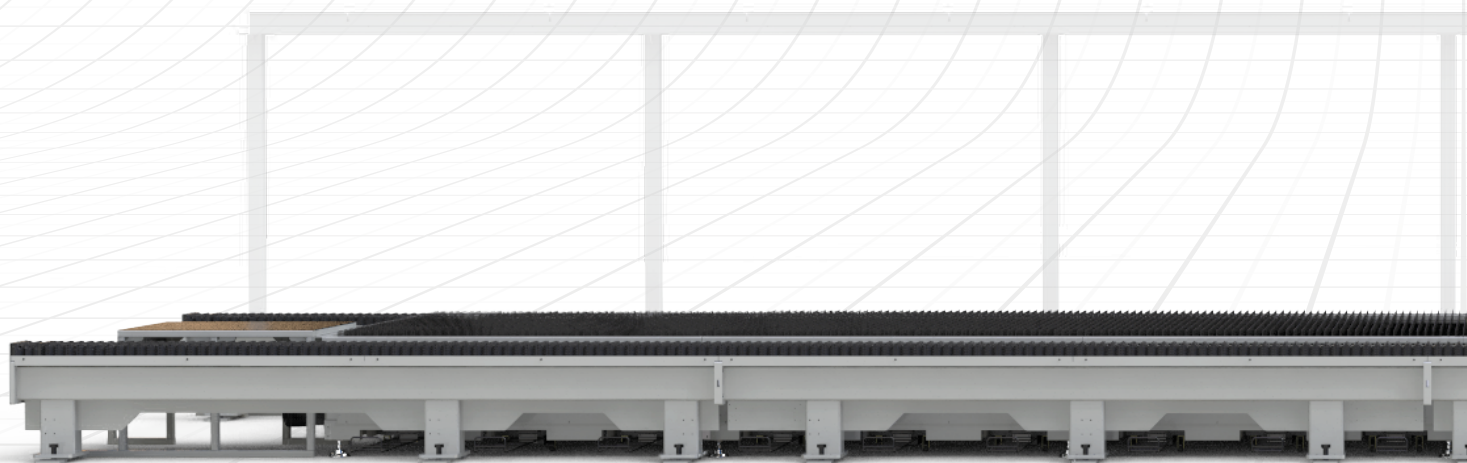

Production is *More Effective Now.*

HD-F 20030

Cutting Length 20.000 mm

Cutting Width 3.000 mm

Power 20 kW

Bevel +/- 45° Cutting Option

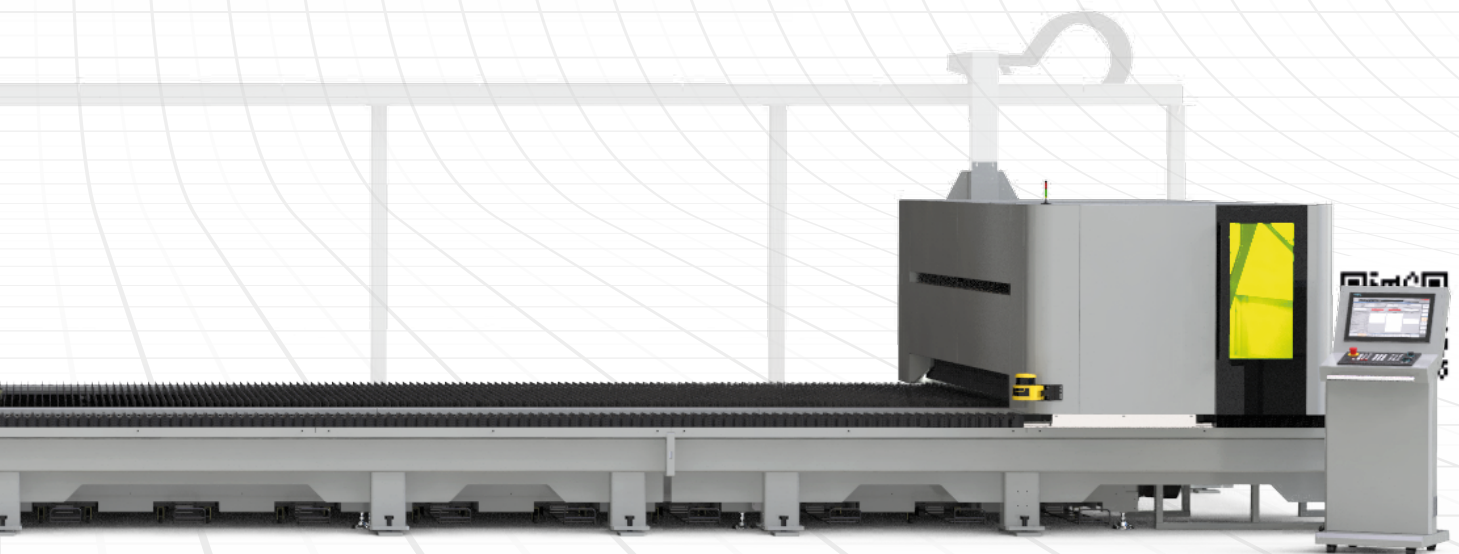

FIBER LASER

HD-F 20030

HD-F 20030 Technical Data

X Axis	20100 mm
Y Axis	3070 mm
Z Axis	165 mm
Max. sheet size	20090 x 3048 mm
X Axis max. speed	60 m/min.
Y Axis max. speed	60 m/min.
Z Axis max. speed	30 m/min.
X-Y Axes synch. speed	85 m/min.
X-Y Axes synch. acceleration	14 m/s ²
Positioning tolerance	0.05 mm

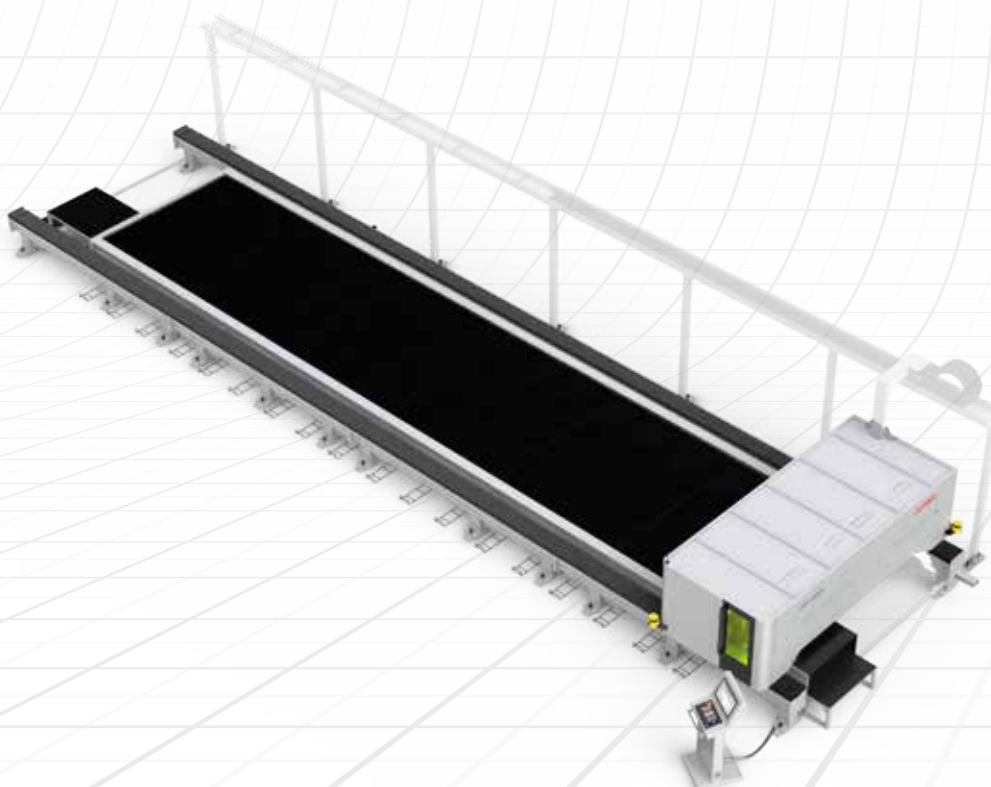

Automatic Loading – Unloading Units Solutions For Your Job

- Manual loading-unloading systems
- Semi automatic loading-unloading systems
- Automatic loading-unloading systems

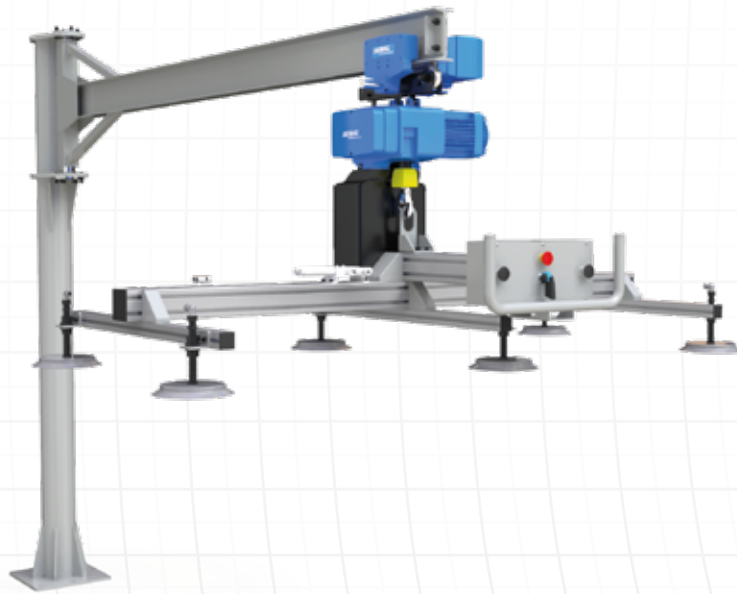

M-LOADER 3015 / 4020		
Technical Data	3015	4020
Sheet Length (Max.)	500 - 3000 mm	500 - 4000 mm
Sheet Width (Max.)	500 - 1500 mm	500 - 2000 mm
Sheet Thickness	10 mm	6 mm
Max. Loading Capacity	360 kg	450 kg
Vacuum Pad Qty.	6 sec.	8 sec.
Rotation angle (Max.)	260°	260°
CONSUMPTION VALUES		
Electricity	0.5 kW	0.5 kW
Compressed Air	3 m ³ /h - 7 bar	3 m ³ /h - 7 bar

FIBER LASER

D-LOADER 3015 / 4020		
Technical Data	3015	4020
Sheet Length (Max.)	500 - 3000 mm	500 - 4000 mm
Sheet Width (Max.)	500 - 1500 mm	500 - 2000 mm
Sheet Thickness	0,5 - 25 mm	0,5 - 25 mm
Max. Loading Capacity	900 kg	1600 kg
Vacuum Pad Qty.	12 pcs.	18 pcs.
Total Cycle Time	60 - 75 sec.(depends on loading height)	65 - 85 sec.(depends on loading height)
Working Area	4200 x 4100 mm h=2260 mm	5500 x 5400 mm h=2720 mm
Rotation angle (Max.)	90°	90°
Electricity	3 kW	4 kW
Compressed Air	6 m ² /h--7 bar	10 m ² /h--7 bar

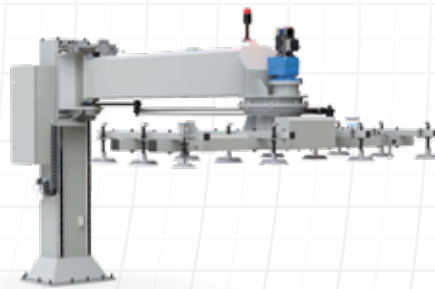

DURMA RAPID SERVER 3015 / 4020			
Technical Specifications	3015	4020	6020
Min. Sheet Size	800 - 800 mm	1000 - 1000 mm	1000 - 1000 mm
Length	1000, 1500, 2000, 2500, 3000 mm	1000, 1500, 2000, 2500, 3000, 3500, 4000 mm	1000, 1500, 2000, 2500, 3000, 3500, 4000, 5000 mm
Width	1000, 1250, 1500 mm	1000, 1250, 1500, 2000 mm	1000, 1250, 1500, 2000 mm
Thickness	0,5 - 25 mm	0,5 - 25 mm	0,5 - 25 mm
Max. Sheet Size	3050 x 1525 mm	4064 x 2032 mm	6096 x 2032 mm
Max. Loadable Sheet Loading Weight	5000 kg	6000 kg	9000 kg
Max. Sheet Loading Height	250 mm	250 mm	250 mm
Cycle Time	50 sec	70 sec	90 sec
Workspace	6950 x 5200 mm h=3400 mm	8000 x 18500 mm h=3850 mm	8000 x 24750 mm h=3850 mm
Dual Sheet Sensor	yes	yes	yes
Sheet Separation System	yes	yes	yes



Production is *More Effective Now.*

DURMA RAPID TOWER 3015 / 4020 / 6020

Technical Specifications	3015	4020	6020
Min. Sheet Size	800 - 800 mm	1000 - 1000 mm	1000 - 1000 mm
Length	1000, 1500, 2000, 2500, 3000 mm	1000, 1500, 2000, 2500, 3000, 3500, 4000 mm	1000, 1500, 2000, 2500, 3000, 3500, 4000, 6000 mm
Width	1000, 1250, 1500 mm	1000, 1250, 1500, 2000 mm	1000, 1250, 1500, 2000 mm
Thickness	0,5 - 25 mm	0,5 - 25 mm	0,5 - 25 mm
Max. Sheet Size	3050 x 1525 mm	4064 x 2032 mm	6096 x 2032 mm
Max. Sheet Metal Loading Weight That Can Be Loaded On The Pallet	3000 kg	4000 kg	5000 kg
Pallet Numbers	10	10	10
Total Loadable Sheet Weight	30000 kg	40000 kg	50000 kg
Max. Sheet Loading Height	85 mm	85 mm	85 mm
Cycle Time	50 sec	60 sec	90 sec
Workspace	6950 x 5200 mm h=3400 mm	8000 x 18500 mm h=3850 mm	8000 x 24750 mm h=3850 mm
Dual Sheet Sensor	yes	yes	yes
Sheet Separation System	yes	yes	yes
Electric Power	23 kW	38 kW	40 kW
Compressed Air	1400 lt/min. - 7 bar	1400 lt/min. - 7 bar	1400 lt/min. - 7 bar



FIBER LASER

SPECIAL APPLICATIONS



Industrial Machines



Steel Service Center



Damper Trailer



Lighting and Energy Poles

Production is *More Effective Now.*

FAST ON SERVICE AND SPARE PARTS

DURMA provides the best level of service and spare parts with qualified personnel and spare parts in stock. Our experienced and professional service personnel are always ready at your service. Our professional training and application enriched courses will give you an advantage to use our machinery.





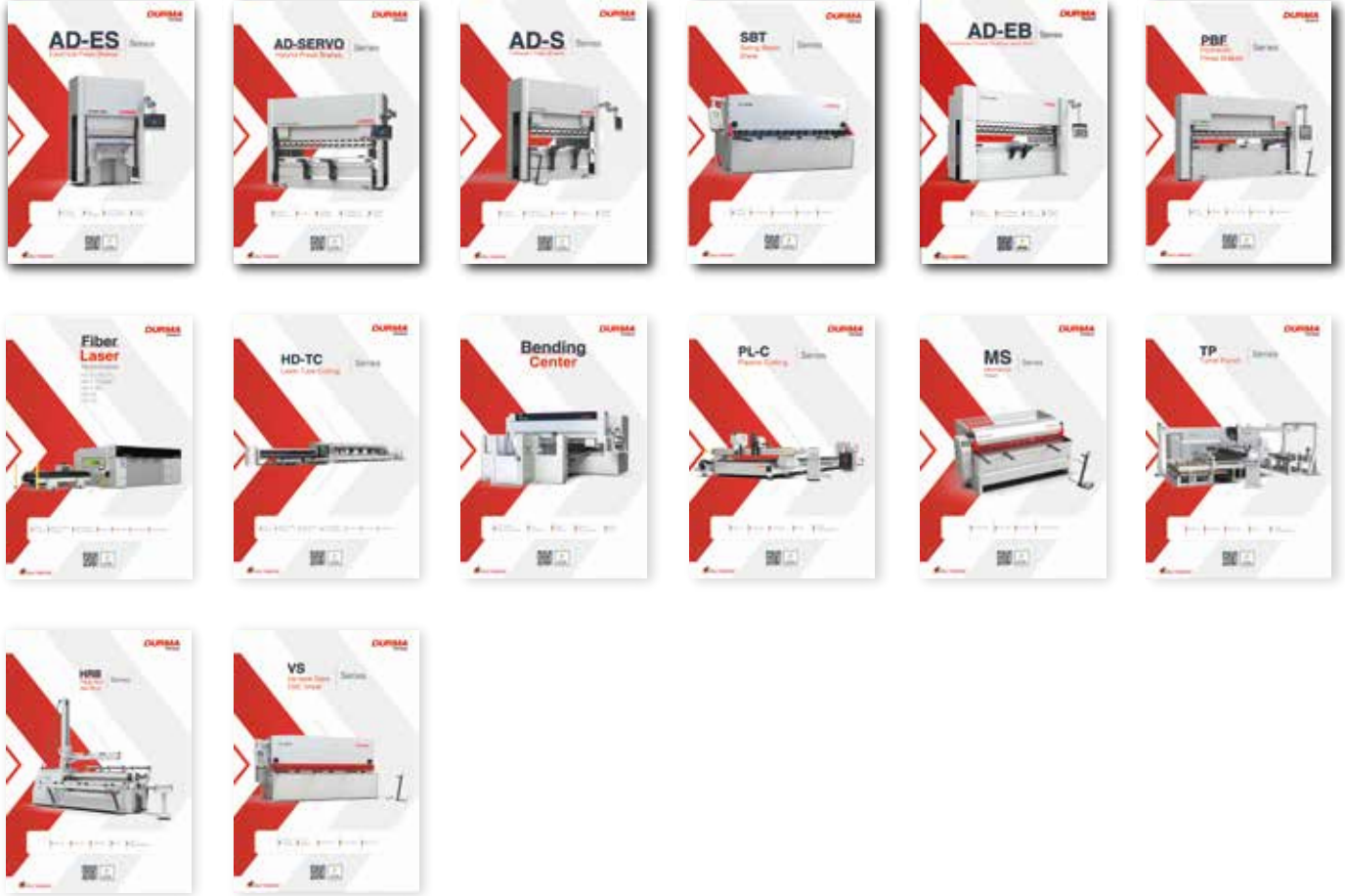

Product Groups

DURMA



Durmazlar Makina San. Tic. A.Ş. has right to change catalogue values and machine technical details without notice.

-  Durma International
-  durmainternational
-  durmaint
-  durmamachines
-  Durmazlar



EN 2024/04/V02



Durmazlar Makina San. ve Tic. A.Ş.
OSB 75. Yıl Bulvarı Nilüfer-Bursa /
Türkiye
P: +90 224 219 18 00
F: +90 224 242 75 80
info@durmazlar.com.tr

www.durmazlar.com.tr